

10 Watt DC/DC Converter using IIC Magnetics

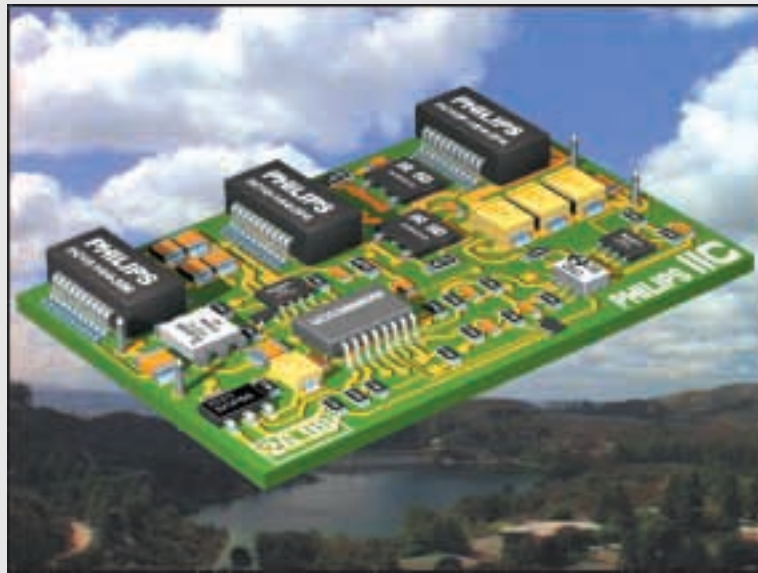

10 Watt DC/DC Converter using IIC Magnetics

Contents

Introduction	3
Converter specification	4
Topology selection	4
Design of IIC magnetics	5
Electrical measurements	8
Thermal measurements	9
Component Selection and PCB layout	10
Circuit diagram	11
Components list	12

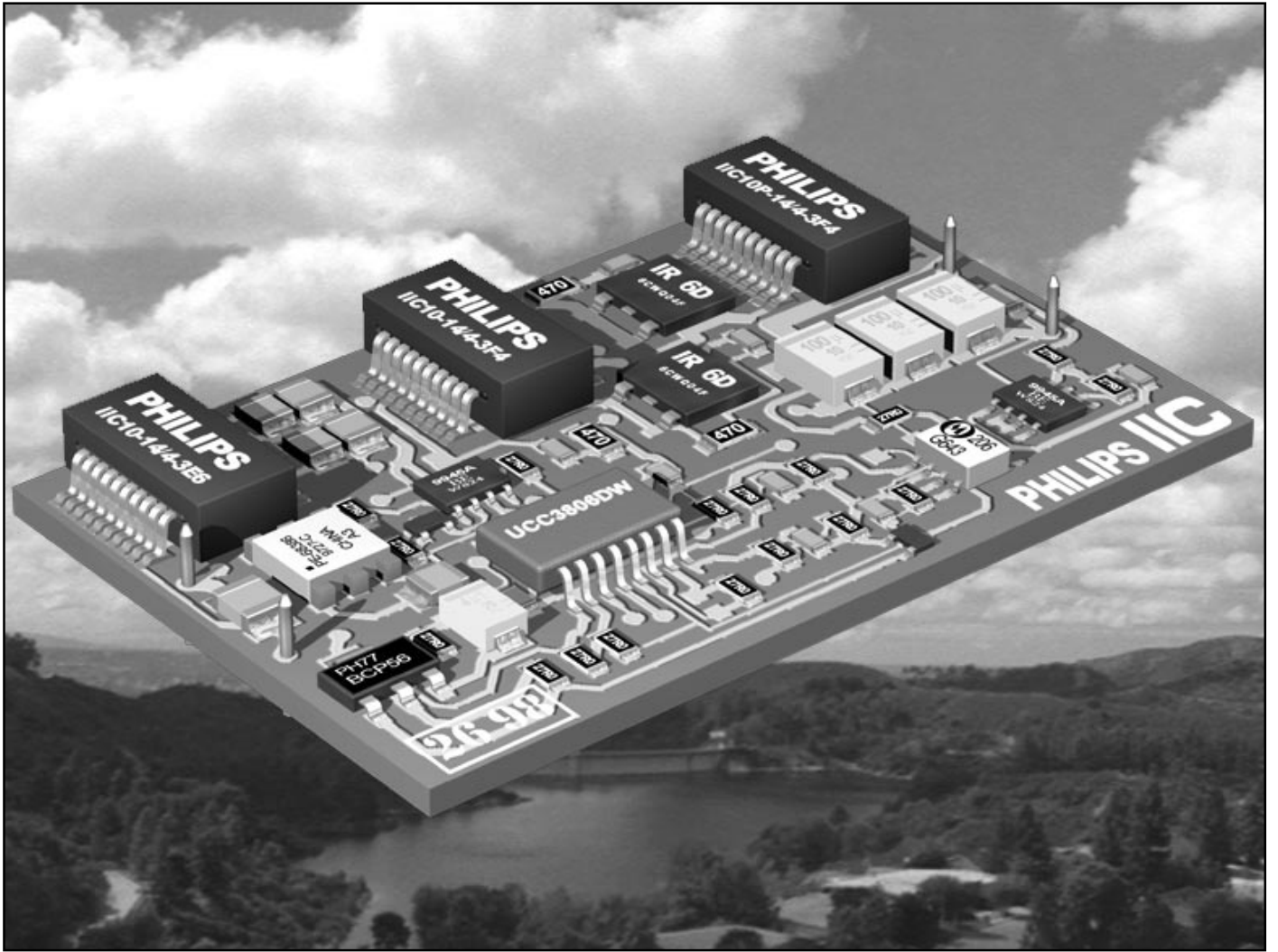

*Fig.1 10 Watt DC/DC Converter using IIC Magnetics
(designed in co-operation with PEI Technologies, Ireland)*

Introduction

For the majority of today's designs it is desirable to have low profile inductive components. This allows designers not only to make low profile equipment, but also to place the inductive device anywhere on the PCB without adaptations to the housing. This is especially true when the inductive component matches the height of other components on the board, for instance IC's which are usually about 3mm high.

One way to achieve this objective is to simply lower existing core designs like E- or RM cores. When these cores get really flat it becomes difficult to accommodate the windings, especially if these must be able to carry large currents.

Windings can be flattened to adapt them to the shape of the component, as in planar magnetics. In the fully integrated planar device the possibility to use the copper layer on the PCB as a winding is exploited for the first time.

Another way to do this is demonstrated in the new Integrated Inductive Component (IIC), presented in this brochure. This product consists of a rectangular ferrite sleeve with an inserted copper lead frame. This sleeve is pressed in one piece although the slot is only 0.75 mm high, and it can also comprise a partial airgap. The lead frame is encapsulated with a high tech thermoplastic material to keep the leads together and to insulate them from the ferrite core.

After insertion the leads are bent in a so-called gull wing shape to form contact pads, just like with most standard SMD IC's. In fact, the finished product really looks like an IC from the outside. It closely resembles the SOT outline and can be handled by standard pick and place equipment as well as soldered together with other IC's on the board (reflow only).

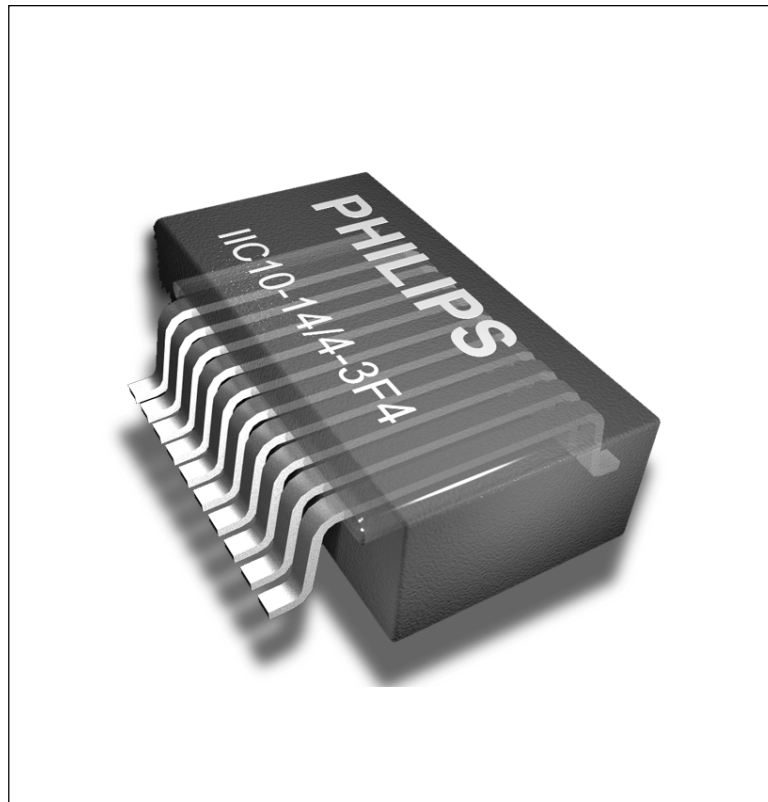

Fig.2 View inside an IIC model

The leads in the moulding form one half of a winding which is completed by a track on the PCB. In this way, depending on the PCB layout, one or more inductive components with up to 10 turns can be constructed. The same product can be applied to make a single inductor with 10 turns or 2 with 5 turns etc.

The IIC design can perform several magnetic functions, depending on the material and the presence of a partial airgap.

The aim of the demonstration board is to show the versatility of Philips' new Integrated Inductive Components (IIC).

To demonstrate the use of the components in several magnetic functions, they are applied in the design of a high frequency DC/DC converter. The IIC's are assembled onto a double-sided PCB just like the other SMD components. Because of the extreme flatness of IIC as well as the other components the overall thickness of the converter is as low as 5.6 mm.

Converter Specification

The specification of the converter is similar to that of commercially available converters but some features have been omitted (e.g. output voltage adjust, short circuit protection). The use of IIC components will not have any impact on these features.

The converter is in open frame format, designed to operate below an ambient temperature of 40°C. This has avoided the need to use heatsinking.

Output power	10 W
Output voltage	5 V
Load regulation	± 1% max.
Line regulation	± 1% max.
Ripple and noise	± 1% max.
Short circuit protection	None
Input voltage	18 - 30 Vdc
Input current	1 A max.
Efficiency (typical)	80%
Isolation voltage	500 V
Outline dimensions	65.5 × 41 × 5.6 mm
Ambient temperature	- 40 °C to + 40 °C
Cooling	Natural convection

Table 1 Converter specification

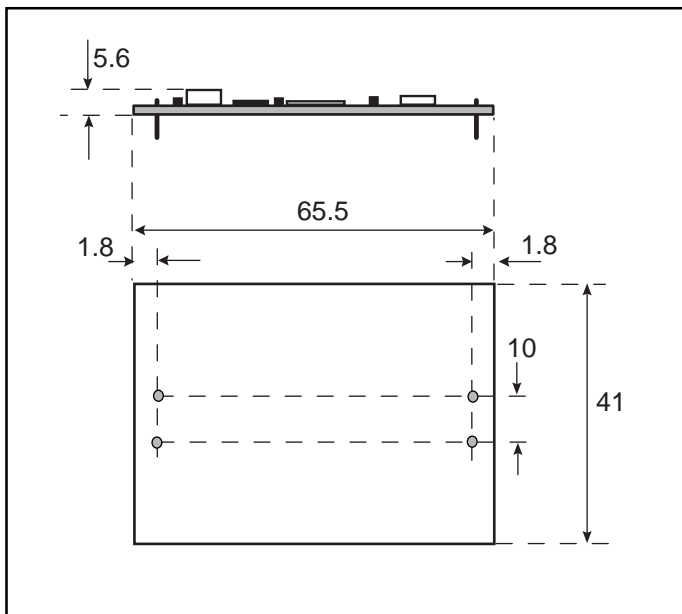

Fig.3 Outline drawing of the converter

Topology Selection

Introduction

Three topologies were considered for this power converter: half-bridge, flyback and forward. The limited number of turns on the IIC components (maximum of 10) has a significant impact on the choice of topology. The optimum use of these components as power transformers is at high operating frequencies and relatively low input voltages. The specified isolation voltage for the IIC10 is 500 V. This is satisfactory for many DC/DC designs. Due to the short distance between its leads, the product is not suitable for use as a safety isolation transformer.

The most common topologies used in commercial DC/DC converters at this power level are flyback and forward.

The flyback converter does not require an output inductor and offers the cheapest solution in low power converters. Since the purpose of this demonstrator is to show the IIC in the function of output choke as well, this topology was not chosen.

The forward converter is more popular than the half bridge at this power level because the half-bridge converter requires two primary side switches and an isolated high side driver. However using the IIC's, the half-bridge has significant benefits that outweigh these disadvantages.

In a half bridge converter the voltage across the primary winding of the power transformer is equal to half the supply voltage. As a result the peak flux density is half that what would be observed in a forward converter operating in similar conditions. Also on the secondary side of the converter the inductor is operating at twice the primary frequency and consequently the inductance can be a lower value to maintain the same ripple current.

Advantages of Half-Bridge Circuit for the demonstration of IIC.

An estimation of the losses expected in the power transformer for both the half-bridge and the forward converter is shown in Table 2. It compares the estimated losses at operating frequencies between 300 and 600kHz (at the primary side).

	Forward	Half-bridge	Forward	Half-bridge	Forward	Half-bridge
V _{pri} (V)	17.5	8.75	17.5	8.75	17.5	8.75
Frequency (kHz)	300	300	400	400	500	500
N _p	6	4	6	4	6	4
N _s	3	3	3	3	3	3
D _{max}	0.63	0.42	0.63	0.42	0.63	0.42
t _{on} (μs)	2.1	1.41	1.57	1.09	1.26	0.84
A _e (mm ²)	11.7	11.7	11.7	11.7	11.7	11.7
B _{pk} (mT)	262	131	196	102	157	78
V _e (mm ³)	338	338	338	338	338	338
P _v (mW/cm ³)	9500	1270	6700	1000	5200	690
P _c (W)	3.2	0.43	2.3	0.34	1.8	0.23

Table 2 Comparison between Forward and Half-bridge converter

Design of IIC Magnetics

For the design of the magnetic functions it is important to know the voltage across the power transformer (T1) and the output inductor as well as the resulting currents. The primary voltage, rectified secondary voltage and the inductor current are shown in Fig. 4.

In a half bridge converter the frequency seen by the output inductor and the output capacitors is effectively twice that of the primary side due to the full wave rectification of the secondary voltage by diodes D1 and D2. The switching period T_{SEC} is equal to half that of T_{PRI}.

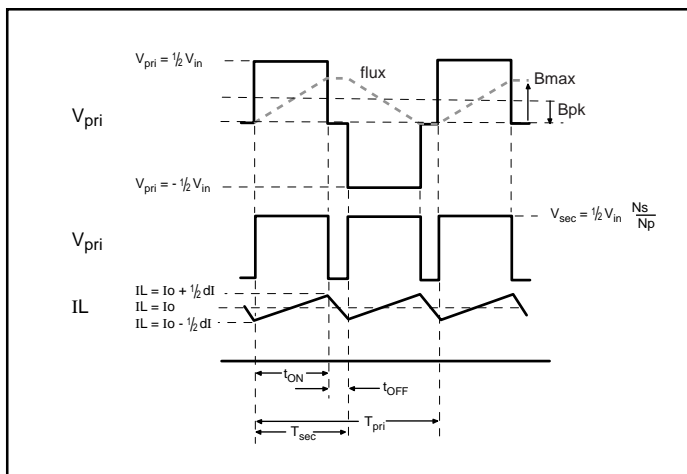

Fig.4 Voltage and current in the converter

The duty cycle is defined as the ratio of the on time of the primary MOSFETS (M1 and M2) to the total time of a switching period:

$$D = \frac{t_{ON}}{T_{SEC}} = \frac{t_{ON}}{t_{ON} + t_{OFF}}$$

The on-time of the MOSFETs is determined by the equation:

$$t_{ON} = T_{SEC} \times \frac{V_o}{\frac{1}{2}V_{in}} \times \frac{N_p}{N_s} \times \frac{1}{\eta}$$

where,

- **V_o** is the output voltage
- **V_{in}** is the input voltage
- **N_p** is the number of primary turns on the power transformer
- **N_s** is the number of secondary turns on the power transformer
- **η** is the efficiency of the converter

Power Transformer Design

In designing the power transformer with an IIC the choice of the number of turns to be placed on the primary and secondary side of the transformer is limited.

The total number of turns for the standard IIC10 is restricted to a maximum of 10. For the half bridge converter three windings are required, 1 primary winding and 2 secondary windings.

The turns ratio of the power transformer can be determined with the equation:

$$\frac{N_s}{N_p} \geq \frac{V_o}{\frac{1}{2}V_{in_{min}}} \times \frac{1}{\eta} \times \frac{1}{D}$$

The maximum duty cycle achievable is set at 0.9 due to the limitations of the control IC. It is desirable to run the converter at the highest possible duty cycle to achieve the maximum efficiency. Low duty cycles cause larger peak currents and thus increase conduction losses in components. The expected efficiency is around 80 %. The minimum input voltage is 18V and consequently:

$$\frac{N_s}{N_p} \geq \frac{5}{9} \times \frac{1}{0.83} \times \frac{1}{0.9}$$

$$\Rightarrow \frac{N_s}{N_p} \geq 0.74$$

With a total number of turns of 10 the best choice to satisfy the above equation is 4 primary turns and 3 turns for both secondary windings. In calculating the losses in the transformer it is important that the on time of the MOSFET's is known as it will vary with the input voltage. Using the equation:

$$t_{ON} = T_{SEC} \times \frac{V_o}{\frac{1}{2}V_{in}} \times \frac{N_p}{N_s} \times \frac{1}{\eta}$$

and operating at 800 kHz (secondary side frequency) the on time at different supply voltages is shown in Table 3.

V _{in} (V)	t _{ON} (μs)
18	1.09
24	0.82
30	0.64
36	0.54

Table 3 On-time for several input voltages

Loss Calculations

The following tables show estimations of winding and core losses. The following points should be noted:

- The core losses are calculated at 400 kHz (primary side frequency) using the published material constants and loss formulas for 3F4.
- A 70 μm layer of copper is assumed to calculate copper loss.
- Losses are calculated at a the nominal supply voltage of 24 V.
- The DC resistance of a turn of the transformer is taken to be 8.5 mΩ.
- AC copper losses are not calculated.

Primary turns	4
Total resistance (mΩ)	34
Primary current (A _{RMS})	1.2
Primary loss (W)	0.048
Secondary turns	2 × 3
Total resistance (mΩ)	51
Secondary current (A _{RMS})	1.6
Secondary loss (W)	0.13
Total copper loss (W)	0.178

Table 4 Survey of winding losses

Core Loss

The peak flux density in the transformer is calculated using the formula:

$$B_{pk} = \frac{V_{pr} \times T_{ON}}{N_{pri} \times A_e}$$

and the on-time, taken from Table 3, is 0.82 μs. The calculation of the core loss in the power transformer operating at 400 kHz is shown in Table 5.

Primary voltage (V)	12
Frequency (kHz)	400
Primary turns	4
t _{ON} (μs)	0.82
A _e (mm ²)	11.7
B _{pk} (mT)	105
Ve (mm ³)	338
P _v (mW/cm ³)	1050
Loss (W)	0.35

Table 5 Estimation of core losses at 400 kHz

Output Inductor

The voltage across the output inductor and the resultant current in the inductor is shown in Fig.4. Ideally the ripple current should be no more than ±20% of the rated output current.

This is to ensure that the output capacitors are not subjected to large ripple currents.

Large peak currents have the effect of increasing converter switching losses as they occur at the point switching devices commutate.

The inductance of IIC10P-14/4-3F4 (10 turns) drops off gradually when DC bias current is applied. The inductance is measured to be approximately 3 μH at 2 A. Using the formula:

$$dI = \frac{V_L \times dt}{L}$$

the ripple current in the inductor is calculated and shown in Table 6. The table shows the variation in the peak to peak ripple when the input voltage varies from 18 V to 36 V.

V _{in} (V)	t _{ON} (μs)	t _{OFF} (μs)	dI _L (L= 3μH) (A)
18	1.09	0.16	0.29
24	0.82	0.43	0.78
30	0.64	0.61	1.10
36	0.54	0.71	1.28

Table 6 Estimation of ripple current

Output Capacitor Requirements

Output ripple voltage is calculated using the formula:

$$dVo = \left(\frac{1}{C} \int dI dt\right) + (dI \times ESR)$$

where ESR= Equivalent Series Resistance of the output capacitors.

The first term is much smaller than the second due the high capacitance (>100 μF) of the output capacitors. Because of that the ripple voltage can be expressed as:

$$dVo = dI \times ESR$$

The worst case is at maximum input voltage where the peak to peak ripple current at a load of 2 A is 1.28 A (Table 6).

For a required ripple voltage of less than 50 mV the output capacitor should therefore have an ESR of less than 39 mΩ.

Input EMI-suppression choke

The input choke L2 combined with C2 and the combination of C3,C4,C19,C20 creates a ‘π filter’ at the front end of the converter (see Fig.15). The noise levels with and without C2 and L2 are shown in Fig. 5 and 6.

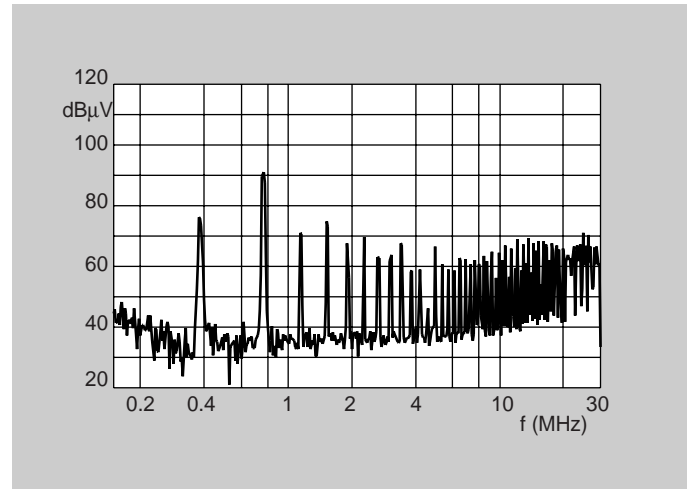

Fig.5 Noise level without π filter

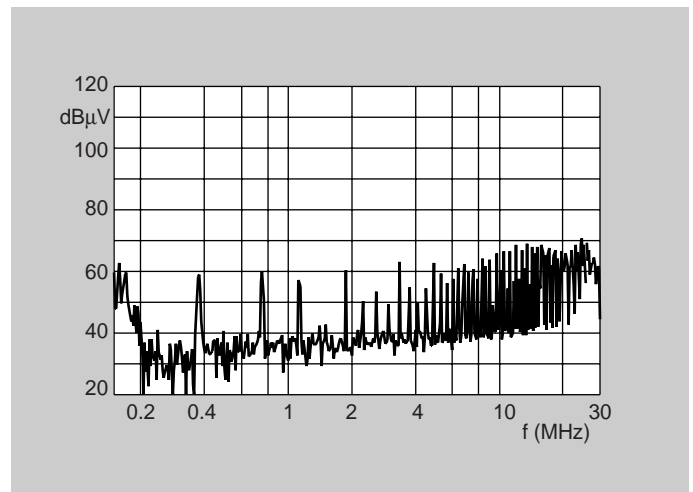

Fig.6 Noise level with π filter

Frequency (MHz)	Noise level (dBμV)	
	Without filter	With filter
0.4	76	59
0.8	91	60
1.2	71	57
1.6	75	43
2	67	60

Table 7 Comparison of noise levels

Electrical Measurements

Voltage Regulation

Recordings are taken of the output voltage as the input voltage and the load are varied. Results are shown in Table 8 below.

Input voltage (V)	Output voltage (V)		
	$I_o = 0.2 \text{ A}$	$I_o = 1 \text{ A}$	$I_o = 2 \text{ A}$
18	4.993	4.990	4.989
24	4.993	4.991	4.989
30	4.993	4.992	4.990
36	4.994	4.992	4.990

Table 8 Regulation figures for converter

Efficiency

The efficiency of the converter is measured at various input voltages at full and at half load. The results are shown in the table below and Fig. 7.

V_{in} (V)	Input power (W)	Output power (W)	Efficiency (%)
18	12.55	10.08	80.3
20	12.73	10.06	79.0
22	13.05	10.05	77.0
24	12.97	10.06	77.6
26	13.49	10.06	74.6
28	13.50	10.06	74.5
30	13.74	10.07	73.3

Table 9 Efficiency of the converter

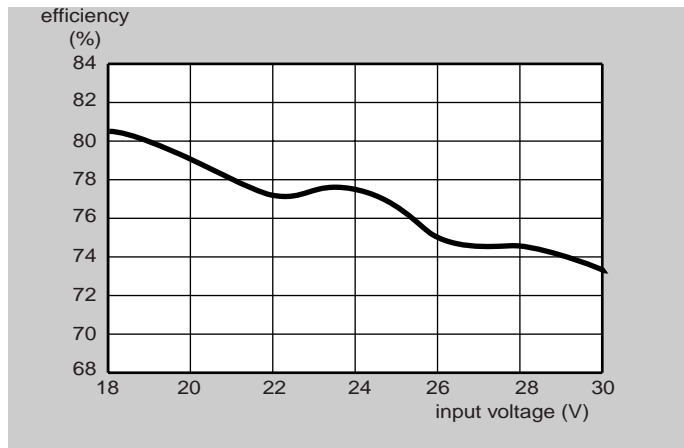

Fig.7 Converter efficiency as a function of input voltage

Output Ripple and Noise

The AC content of the output voltage is shown in Fig. 8

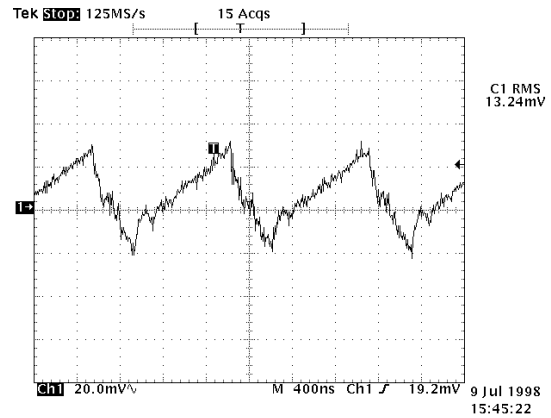

Fig.8 Output ripple and noise

Circuit Waveforms

In Fig.9 the gate drive voltages for the MOSFETs are shown. In the tested unit both are switching at 382 kHz. Fig.10 shows the un-rectified secondary voltage.

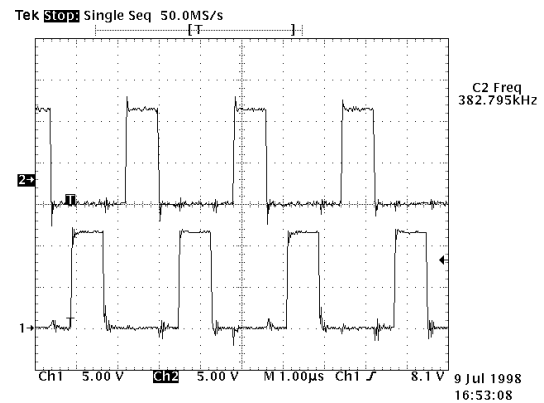

Fig.9 Gate drive for top MOSFET M1 (1.5 V/div) and lower MOSFET M2 (2.5 V/div)

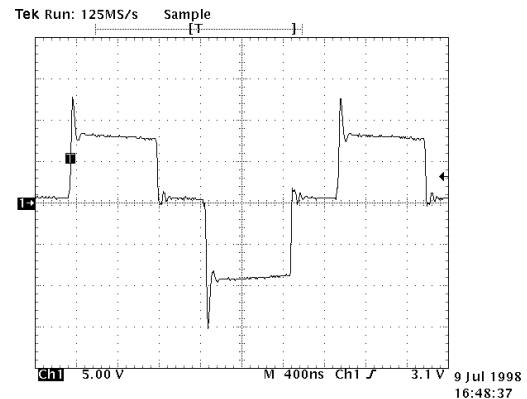

Fig.10 Transformer secondary voltage (5 V/div)

Thermal Measurements

Temperature rise of components

Temperature measurements were carried out during normal operation of the converter at an ambient temperature of 22 °C. This gives a good indication of the thermal stress on the separate components. Results are presented in Fig.11.

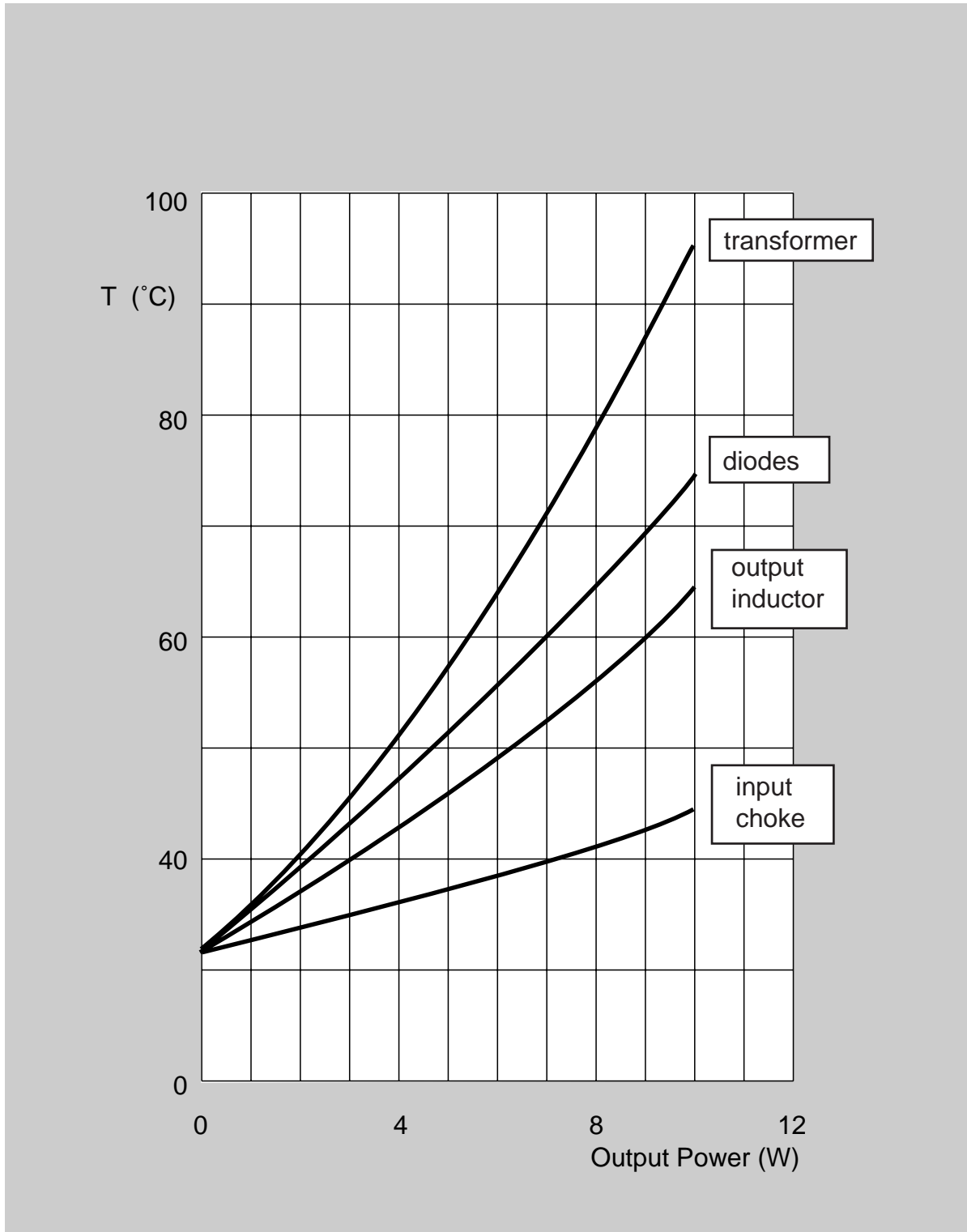

Fig.11 Operating temperature of components as a function of output power at an input voltage of 24 V.

Schematic and Component Selection.

The schematic for the half-bridge converter is shown in Fig.16. All magnetics, except the pulse transformer for the upper MOSFET, are designed using IIC components.

The type numbers, their application and the relevant reference designator are shown in Table 10. Other components selected are manufactured by various companies and in most cases components are obtainable from more than one source. These components are selected on the basis of their specification and cost. The complete bill of material is shown in Table 11.

Application	Reference	Type Number
Input choke	L2	IIC10-14/4-3E6
Power transformer	T1	IIC10-14/4-3F4
Output inductor	L3	IIC10P-14/4-3F4

Table 10 Applied IIC components

PCB layout

A double-sided PCB with 70 µm copper layers is used to mount all SMD components. Layout and track patterns are shown in the figures below.

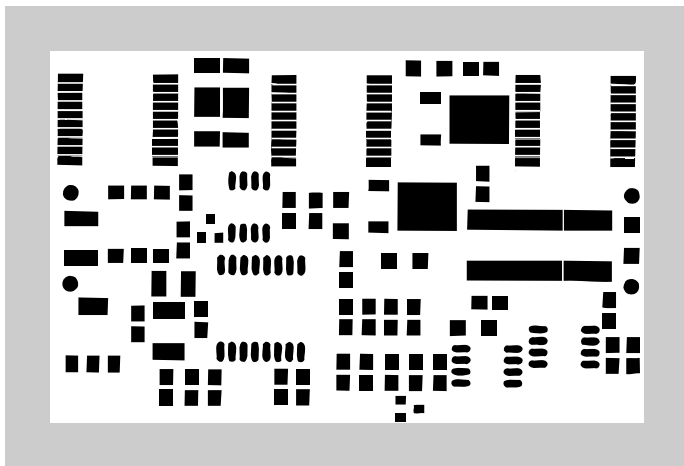

Fig. 12 Top layer photo-resist

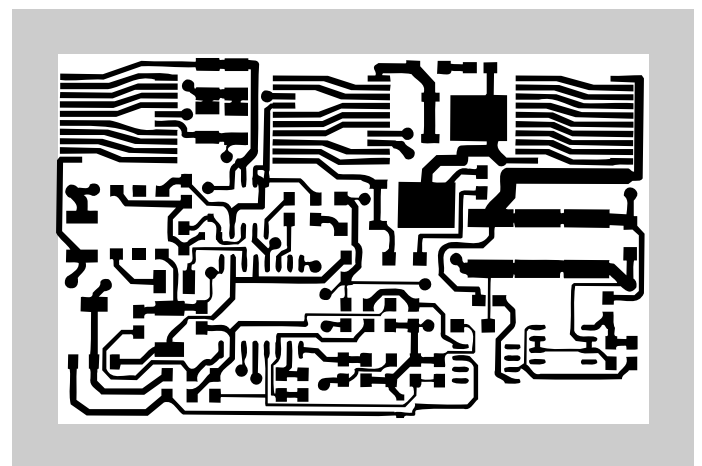

Fig. 13 Top layer tracks

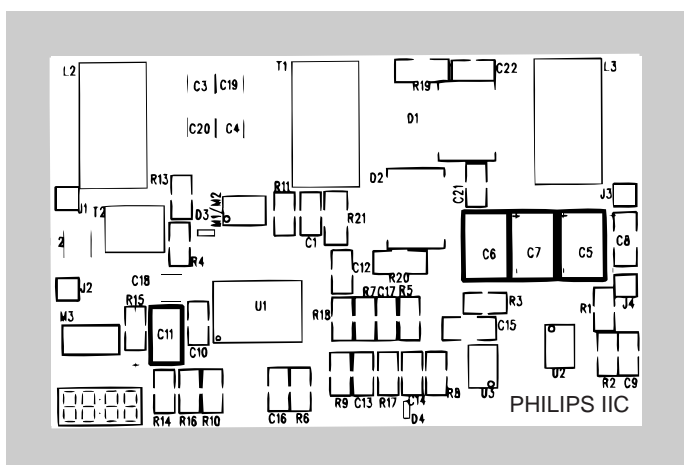

Fig. 14 Component layout

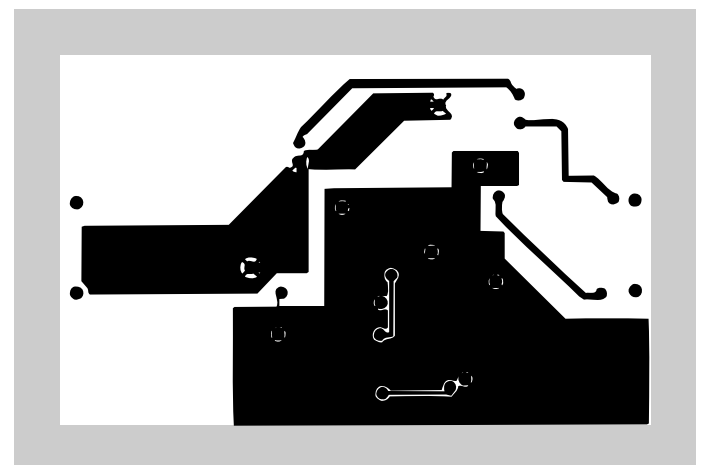

Fig. 15 Bottom layer tracks

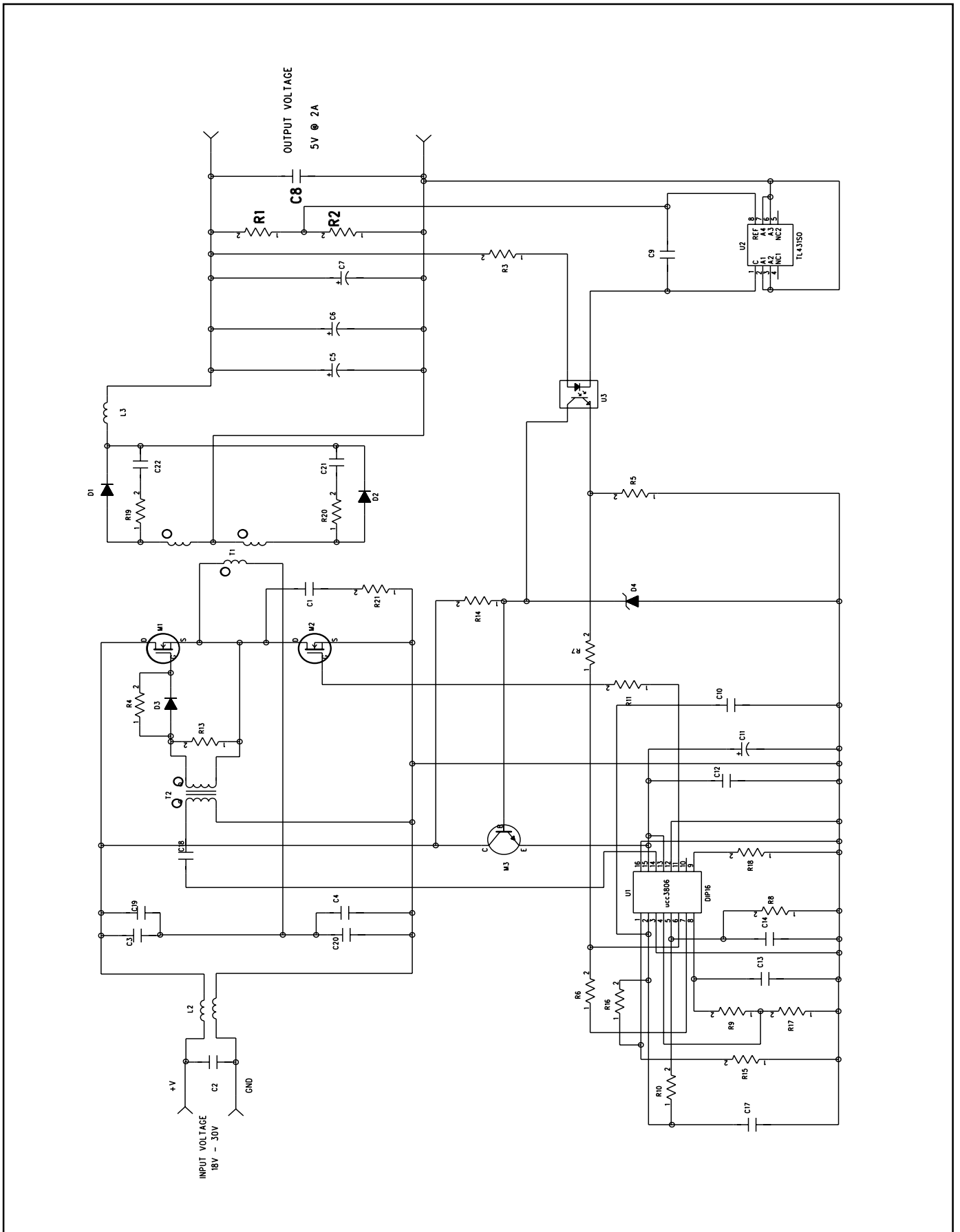

Fig.16 Circuit diagram

Components list

Reference	Part no./series	Description	Package	Manufacturer
D1, D2	6CWQ04F/ (MBRD640CT)	6.6A, 40V diode	D - Pak	I.R./ (Motorola)
D3	BAT54	30V, 200mA Schottky diode	SO T-23	Philips
D4	BZX84C12	12V Zener diode	SO T-23	Philips
M1/2	S19945AEY	60V, 3A, dual MO SFET	S08	Temic
M3	BCP56	80V, 0.5A, NPN transistor	SO T-223	Philips
C1, C13	0805CG102J9BB	1nF, 50V, NPO	0805	Philips
C2	430862G	1μF, 50V, X7R	1812	Philips
C3, C4, C18, C19, C20	444112R	1μF, 25V, X7R	1210	Syfer
C5, C6, C7	TAJD107K010R	100μF, 10V	D	AVX
C8	428527G	100nF	1206	Philips
C9, C10, C12, C14, C17	08052R104K8BB	100nF, 25V	0805	Philips
C11	TAJD475K025R	4μF, 25V	C	AVX
C15	423787C	1nF, 500V	1206	Syfer
C21, C22	436575B	390pF, 50V	0805	Philips
U1	UCC3806DAW	16 Pin SO IC PWM controller	SO 16DW	Unitrode
U2	TL431CD	100mA, 3V to 36V voltage regulator	SO 8	ST
U3	MOC206	optocoupler	SO 8	Motorola
L2	IIC10-14/4-3E6	input choke	IIC10	Philips
T1	IIC10-14/4-3F4	power transformer	IIC10	Philips
L3	IIC10P-14/4-3F4P	output inductor	IIC10	Philips
T2	PE-68386	pulse transformer, 1:1		Pulse
R1, R2	RC11 series	1K	0805	Philips
R3	RC11 series	220R	0805	Philips
R4, R11	RC11 series	10R	0805	Philips
R5, R17	RC12 series	1K6	0805	Philips
R6, R8, R9, R10, R13	RC11 series	10K	0805	Philips
R7	RC11 series	33K	0805	Philips
R14, R18	RC11 series	3K3	0805	Philips
R15, R16	RC11 series	24K	0805	Philips
R21	RC01 series	68R	1206	Philips
R19, R20	RC01 series	47R	1206	Philips

Table 11 List of components used for the demo converter

Magnetic Products NAFTA Sales Offices

Alabama	Over and Over, Inc., Charlotte, NC	(708) 583-9100
Alaska	Eclipse Marketing Group, Redmond, WA	(206) 885-6991
Arizona	Harper and Two, Tempe, AZ	(602) 804-1290
Arkansas	Philips Components, Willoughby, OH	(440) 269-8585
California - Northern	Criterion Sales, Santa Clara, CA	(408) 988-6300
California - Southern	Harper and Two, Signal Hill, CA	(801) 264-8050
Colorado	Philips Components, Willoughby, OH	(440) 269-8585
Connecticut	Philips Components, Woburn, MA	(617) 932-4748
Delaware	Philips Components, Woburn, MA	(617) 932-4748
Florida	Over and Over, Charlotte, NC	(704) 583-9100
Georgia	Over and Over, Charlotte, NC	(704) 583-9100
Hawaii	Harper and Two, Signal Hill, CA	(310) 424-3030
Idaho - Northern	Eclipse Marketing Group, Redmond, WA	(206) 885-6991
Idaho - Southern	Electrodyne, Inc., Salt Lake City, UT	(801) 264-8050
Illinois - Northern	Philips Components, Willoughby, OH	(440) 269-8585
Illinois - Quad Cities	Lorenz Sales, Cedar Rapids, IA	(319) 377-4666
Illinois - Southern	Lorenz Sales, St. Louis, MO	(314) 997-4558
Indiana - Northern	Corrao Marsh, Fort Wayne, IN	(219) 482-2725
Indiana - Central and Southern	Corrao Marsh, Greenfield, IN	(317) 462-4446
Iowa - All except Quad Cities	Lorenz Sales, Cedar Rapids, IA	(319) 377-4666
Kansas - Northeast	Lorenz Sales, Overland Park, KS	(913) 469-1312
Kansas - All except Northeast	Lorenz Sales, Wichita, KS	(316) 721-0500
Kentucky	Corrao Marsh, Greenfield, IN	(317) 462-4446
Louisiana	Philips Components, Willoughby, OH	(440) 269-8585
Maine	Philips Components, Woburn, MA	(617) 932-4748
Maryland	Philips Components, Willoughby, OH	(440) 269-8585
Massachusetts	Philips Components, Woburn, MA	(617) 932-4748
Michigan	Philips Components, Willoughby, OH	(440) 269-8585
Minnesota	Electronic Component Sales, Minneapolis, MN	(612) 946-9510
Mississippi	Over and Over, Charlotte, NC	(704) 583-9100
Missouri - Eastern	Lorenz Sales, St. Louis, MO	(314) 997-4558
Missouri - Western	Lorenz Sales, Overland Park, KS	(913) 469-1312
Montana	Electrodyne, Inc., Salt Lake City, UT	(801) 264-8050
Nebraska	Lorenz Sales, Cedar Rapids, IA	(319) 377-4666
Nevada - Central and Northern	Criterion Sales, Santa Clara, CA	(408) 988-6300
Nevada - Southern	Harper and Two, Tempe, AZ	(602) 804-1290
New Hampshire	Philips Components, Woburn, MA	(617) 932-4748
New Jersey	Philips Components, Woburn, MA	(617) 932-4748
New Mexico	Harper and Two, Tempe, AZ	(602) 804-1290
New York - Western	Philips Components, Willoughby, OH	(440) 269-8585
New York - All other	Philips Components, Woburn, MA	(617) 932-4748
North Carolina	Over and Over, Charlotte, NC	(704) 583-9100
North Dakota	Electronic Component Sales, Minneapolis, MN	(612) 946-9510
Ohio	Philips Components, Willoughby, OH	(440) 269-8585
Oklahoma	Philips Components, Willoughby, OH	(440) 269-8585
Oregon	Eclipse Marketing Group, Beaverton, OR	(503) 642-1661
Pennsylvania - Western	Philips Components, Willoughby, OH	(440) 269-8585
Pennsylvania - Eastern	Philips Components, Woburn, MA	(617) 932-4748
Rhode Island	Philips Components, Woburn, MA	(617) 932-4748
South Carolina	Over and Over, Charlotte, NC	(704) 583-9100
South Dakota	Electronic Component Sales, Minneapolis, MN	(612) 946-9510
Tennessee	Over and Over, Charlotte, NC	(704) 583-9100
Texas	Philips Components, Willoughby, OH	(440) 269-8585
Utah	Electrodyne, Inc., Salt Lake City, UT	(801) 264-8050
Vermont	Philips Components, Woburn, MA	(617) 932-4748
Virginia	Philips Components, Willoughby, OH	(440) 269-8585
Washington	Eclipse Marketing Group, Redmond, WA	(206) 885-6991
Washington DC	Philips Components, Willoughby, OH	(440) 269-8585
West Virginia	Philips Components, Willoughby, OH	(440) 269-8585
Wisconsin	Philips Components, Willoughby, OH	(440) 269-8585
Wyoming	Electrodyne, Inc., Salt Lake City, UT	(801) 264-8050
Canada	Philips Components, Scarborough, ON	(416) 292-5161
Mexico	Philips Components, El Paso, TX	(915) 772-4020
Puerto Rico	Max Anderson Co., Caperra Heights, PR	(809) 783-6544
Virgin Islands	Max Anderson Co., Caperra Heights, PR	(809) 783-6544

Philips Components – a worldwide company

Australia: Philips Components Pty Ltd., NORTH RYDE,
Tel. +61 2 9805 4455, Fax. +61 2 9805 4466

Austria: Österreichische Philips Industrie GmbH, WIEN,
Tel. +43 1 60 101 12 41, Fax. +43 1 60 101 12 11

Belarus: Philips Office Belarus, MINSK,
Tel. +375 172 200 924/733, Fax. +375 172 200 773

Benelux: Philips Nederland B.V., EINDHOVEN, NL,
Tel. +31 40 2783 749, Fax. +31 40 2788 399

Brazil: Philips Components, SÃO PAULO,
Tel. +55 11 821 2333, Fax. +55 11 829 1849

Canada: Philips Electronics Ltd., SCARBOROUGH,
Tel. +1 416 292 5161, Fax. +1 416 754 6248

China: Philips Company, SHANGHAI,
Tel. +86 21 6354 1088, Fax. +86 21 6354 1060

Denmark: Philips Components A/S, COPENHAGEN S,
Tel. +45 32 883 333, Fax. +45 31 571 949

Finland: Philips Components, ESPOO,
Tel. +358 9 615 800, Fax. +358 9 615 80510

France: Philips Composants, SURESNES,
Tel. +33 1 4099 6161, Fax. +33 1 4099 6493

Germany: Philips Components GmbH, HAMBURG,
Tel. +49 40 2489-0, Fax. +49 40 2489 1400

Greece: Philips Hellas S.A., TAVROS,
Tel. +30 1 4894 339/+30 1 4894 239, Fax. +30 1 4814 240

Hong Kong: Philips Hong Kong, KOWLOON,
Tel. +852 2784 3000, Fax. +852 2784 3003

India: Philips India Ltd., MUMBAI,
Tel. +91 22 4930 311, Fax. +91 22 4930 966/4950 304

Indonesia: P.T. Philips Development Corp., JAKARTA,
Tel. +62 21 794 0040, Fax. +62 21 794 0080

Ireland: Philips Electronics (Ireland) Ltd., DUBLIN,
Tel. +353 1 7640 203, Fax. +353 1 7640 210

Israel: Rapac Electronics Ltd., TEL AVIV,
Tel. +972 3 6450 444, Fax. +972 3 6491 007

Italy: Philips Components S.r.l., MILANO,
Tel. +39 2 6752 2531, Fax. +39 2 6752 2557

Japan: Philips Japan Ltd., TOKYO,
Tel. +81 3 3740 5135, Fax. +81 3 3740 5035

Korea (Republic of): Philips Electronics (Korea) Ltd., SEOUL,
Tel. +82 2 709 1472, Fax. +82 2 709 1480

Malaysia: Philips Malaysia SDN Berhad,
Components Division, PULAU PINANG,
Tel. +60 3 750 5213, Fax. +60 3 757 4880

Mexico: Philips Components, EL PASO, U.S.A.,
Tel. +52 915 772 4020, Fax. +52 915 772 4332

New Zealand: Philips New Zealand Ltd., AUCKLAND,
Tel. +64 9 815 4000, Fax. +64 9 849 7811

Norway: Norsk A/S Philips, OSLO,
Tel. +47 22 74 8000, Fax. +47 22 74 8341

Pakistan: Philips Electrical Industries of Pakistan Ltd., KARACHI,
Tel. +92 21 587 4641-49, Fax. +92 21 577 035/+92 21 587 4546

Philippines: Philips Semiconductors Philippines Inc.,
METRO MANILA, Tel. +63 2 816 6345, Fax. +63 2 817 3474

Poland: Philips Poland Sp. z.o.o., WARSZAWA,
Tel. +48 22 612 2594, Fax. +48 22 612 2327

Portugal: Philips Portuguesa S.A.,
Philips Components: LINDA-A-VELHA,
Tel. +351 1 416 3160/416 3333, Fax. +351 1 416 3174/416 3366

Russia: Philips Russia, MOSCOW,
Tel. +7 95 755 6918, Fax. +7 95 755 6919

Singapore: Philips Singapore Pte Ltd., SINGAPORE,
Tel. +65 350 2000, Fax. +65 355 1758

South Africa: S.A. Philips Pty Ltd., JOHANNESBURG,
Tel. +27 11 470 5911, Fax. +27 11 470 5494

Spain: Philips Components, BARCELONA,
Tel. +34 93 301 63 12, Fax. +34 93 301 42 43

Sweden: Philips Components AB, STOCKHOLM,
Tel. +46 8 5985 2000, Fax. +46 8 5985 2745

Switzerland: Philips Components AG, ZÜRICH,
Tel. +41 1 488 22 11, Fax. +41 1 481 7730

Taiwan: Philips Taiwan Ltd., TAIPEI,
Tel. +886 2 2134 2900, Fax. +886 2 2134 2929

Thailand: Philips Electronics (Thailand) Ltd., BANGKOK,
Tel. +66 2 745 4090, Fax. +66 2 398 0793

Turkey: Türk Philips Ticaret A.S., GÜLTEPE/ISTANBUL,
Tel. +90 212 279 2770, Fax. +90 212 282 6707

United Kingdom: Philips Components Ltd., DORKING,
Tel. +44 1306 512 000, Fax. +44 1306 512 345

United States:

- Display Components, ANN ARBOR, MI,
Tel. +1 734 996 9400, Fax. +1 734 761 2776
- Magnetic Products, SAUGERTIES, NY,
Tel. +1 914 246 2811, Fax. +1 914 246 0487
- Passive Components, SAN JOSE, CA,
Tel. +1 408 570 5600, Fax. +1 408 570 5700

Yugoslavia (Federal Republic of): Philips Components, BELGRADE,
Tel. +381 11 625 344/373, Fax. +381 11 635 777

Internet:

- Display Components: www.dc.comp.philips.com
- Passive Components: www.passives.comp.philips.com

For all other countries apply to:

Philips Components, Building BF-1, P.O. Box 218, 5600 MD EINDHOVEN,
The Netherlands, Fax. +31-40-27 23 903.

COD19 © Philips Electronics N.V. 1998

All rights are reserved. Reproduction in whole or in part is prohibited without the prior written consent of the copyright owner.
The information presented in this document does not form part of any quotation or contract, is believed to be accurate and reliable and may be changed without notice. No liability will be accepted by the publisher for any consequence of its use. Publication thereof does not convey nor imply any license under patent- or other industrial or intellectual property rights.

Printed in The Netherlands

Document order number: 9398 239 03011

Date of release: 11/98

Philips
Components



PHILIPS

Let's make things better.