

Nazwa / Name T10/6/4-3C90
Numer kodu / Code number 4327 030 35951

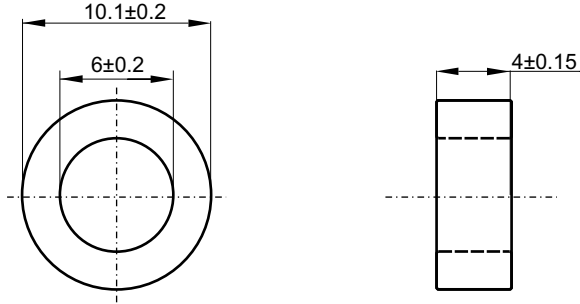

Magnetical dimensions according to: / Właściwości magnetyczne zgodne z: IEC 205

$\Sigma l/A$ (mm ⁻¹)	$\Sigma l/A^2$ (mm ⁻³)	A_e : 8.02 mm ²	l_e : 24.19 mm	V_e : 194 mm ³
3.02	0.38			Weight:/Waga: ≈ 0.92 g

Specified value / Wartości specyfikowane

Symbol Symbol	Specyfification Specyfification (2)	Unit Jednostka	Frequency Częstotliwość f [kHz]	H [A/m]	Equipment (Sprzęt pomiarowy) (1)	Temperature Temperatura t [°C]
Al	1040±25%	nH	10	---	HP-4284A	25±3
Hc	≤22	A/m	10	250		

(1) Or similar / Lub podobny
 (2) Ref $\mu_i \approx 2500$

**VISUAL REQUIREMENTS according to: I-15-002
 KONTROLA WIZUALNA według: I-15-002**

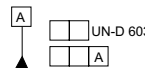
		Tolerances unless otherwise stated Tolerancja (jeśli nie ustalono inaczej) Dimensions Wymiary ±3% Angle Kąt				Name Nazwisko		Signature Podpis		Date Data	
General Roughness Chropowatość		Unit Jednostka mm.		MATERIAL 3C90 acc. to KPN-K1959 MATERIAŁ 3C90 zgodnie z: KPN-K1959		Check Sprawdził		Szczepan Frydrych		UNCONTROLLED COPY generated electronically, conform with original up to the date of its creation KOPIA NIEKONTROLOWANA wygenerowana elektronicznie, zgodna z oryginałem w dniu jego zatwierdzenia	
Scale Skala Brak		PROJ.EURO PROJ.EURO		TYPE NUMBER / TYP		Approval Zatwierdził		Krzysztof Murgrabia			
Status/Status		T10/6/4-3C90		SHEETS STRONY 1 SHEET STRONA 110-02		Other Inne		D C B A		09-03-04	
Issued by: Wydano przez: M.Zagórska / K.S.		SUPERSEDES ZASTĘPUJE		Property of WŁAŚCICIEL		Ferroxcube Polska Sp. z o.o. SKIERNIEWICE, POLAND		DATE DATA 09-03-04		A-4	