



FXT1.2-SLI-X-ATEX

Code: 4330 034 10121

13.56 MHz FERROXTAG ON METAL SCREW BOX ATEX

FEATURES

- ISO/IEC 15693; ISO/IEC 18000-3 Compliant
- 13.56 MHz Operating Frequency
- 1024 Bit User Memory in 32 block x 4 bytes
- Unique Identifier 8 bytes
- Fast Simultaneous Identification (Anticollision)
- Data transfer up to 53kbits/sec

APPLICATIONS

- Metal items identification
- Industrial applications
- LPG Cylinder Tracking
- Handling of solvents
- Explosive atmospheres
- Filling stations
- Due to the hard epoxy sealant, it is specially recommended for applications where the tag is glued to the identified object.

DESCRIPTION

FerroxTag 13.56MHz encapsulated on metal screw box is complaint with the ISO/IES 15693 and ISO/IEC 18000-3 global open standards. This product offers a user accessible memory of 1024 bits, organized in 32 blocks of 4 bytes and an optimized command set.

Specially tuned at such a frequency that they need to be mounted on a metallic item in order to achieve the right 13.56Mhz operating frequency and best performance.

For non potentially explosive atmospheres use FerroxTag screw box FXT1.2-SLI-X. www.ferroxtag.com.

Designed for harsh and potentially explosive environments, the encapsulation protects the device against impacts, making it ideal for industrial applications. Each transponder has a factory programmed 8 bytes unique identifier. Prior to delivery, FerroxTag undergo complete and parametric testing, in order to provide high quality.

SPECIFICATIONS

PART NUMBER	FXT1.2-SLI-X-ATEX
Supported Standard	ISO/IEC 15693; ISO/IEC 18000-3
Passive Resonance Frequency (at the air)	13 MHz \pm 300 KHz, shifts to 13.56 MHz when mounted on a metal surface
Unique identifier	8 bytes
EEPROM memory	1024 bits, 32 blocks x 4 bytes
User programmable memory	28 blocks x 4 bytes
Typical programming cycles	100,000
Data retention time	10 years
Data transfer	Up to 53 Kbits/sec
Typical Reading range	30 cm with 4 watts reader power and 30x30 cm antenna on a metal item
Simultaneous Identification of Tags	Up to 50 tags per second (reader/antenna dependent)
Operating temperature	-25°C to +130°C
IC	NXP-ICODE SLI



FXT1.2-SLI-X-ATEX

Code: 4330 034 10121

MECHANICAL PROPERTIES

Dimensions	25 x 12.5 x 5 mm
Weight	2.5 grams
Case material	POLYAMIDE 66 UL94-V0
Degree of protection	IP68
Colour	White, sealed with black epoxy
Storage temperature	-40°C to +150°C
Sealing material	Black epoxy

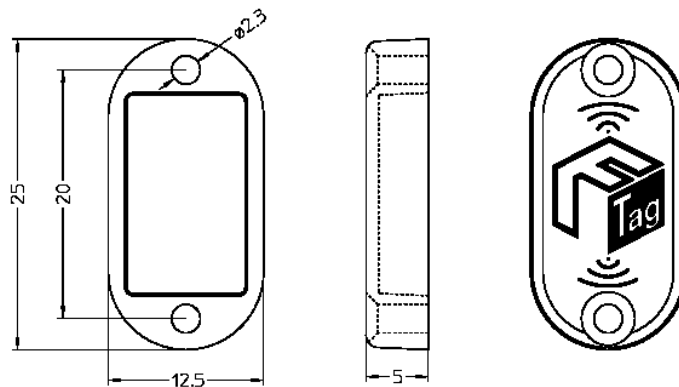

TAG INSTALLATION

It is recommended to install the tag on a corner of the metal item to be identified, or in the closest position to the reader antenna. Optimal performance is achieved by orientating the device towards the reader as shown in the figure.



The right way of installing the tag (screwed or glued) is to put the black epoxy side of the piece against the metal item to be identified. Nevertheless, the tag does not need to be in direct contact with the metal, the distance can vary from 0 to 3 mm.

MEMORY ORGANIZATION

The 1024 bit EEPROM memory is divided in 32 Blocks of 4 bytes. (1 Block = 32 bits). The 64 bit unique identifier (UID=2 blocks) is programmed during the production process. The next 2 blocks are for control (EAS= Electronic Article Surveillance, AFI= Application Family Identifier, DSFID= Data Storage Format Identifier) and write access conditions for the rest of the blocks. With read and write commands only blocks 0 to 27 can be addressed.

	Byte 0	Byte 1	Byte 2	Byte 3	
Block -4	UID 0	UID 1	UID 2	UID 3	} UID n° (64bits) EAS, AFI, DSFID
Block -3	UID 4	UID 5	UID 6	UID 7	
Block -2	Control bytes				
Block -1	Write access conditions				
Block 00	R/W	R/W	R/W	R/W	} User data 28 blocks
Block 01	R/W	R/W	R/W	R/W	
Block 02	R/W	R/W	R/W	R/W	
.....	
.....	
Block 25	R/W	R/W	R/W	R/W	
Block 26	R/W	R/W	R/W	R/W	
Block 27	R/W	R/W	R/W	R/W	

32 bits



ATEX certified

FXT1.2-SLI-X-ATEX

Code: 4330 034 10121

DISCLAIMER

These products are not designed for use in life support appliances, devices, or systems where malfunction of these products can reasonably be expected to result in personal injury. Ferroxcube customers using or selling these products for use in such applications do so at their own risk and agree to fully indemnify Ferroxcube for any damages resulting from such application.