

COIL FORMERS

General data for E13/6/6 coil former

ITEM	SPECIFICATION
Coil former material	polyamide (PA6.6), glass reinforced, flame retardant in accordance with "UL 94V-2"; UL file number E41938(M)
Maximum operating temperature	130 °C, "IEC 60085", class B

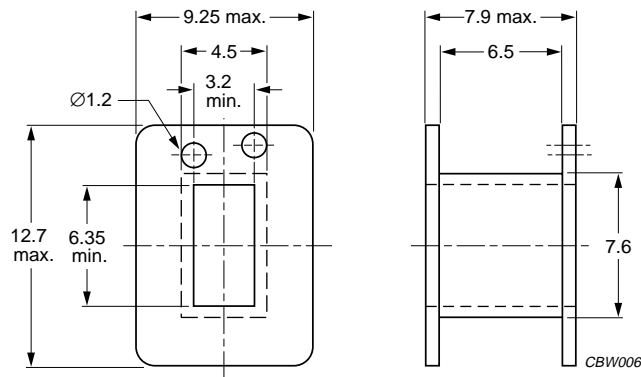

Dimensions in mm.

Fig.2 E13/6/6 coil former.

Winding data for E13/6/6 coil former

NUMBER OF SECTIONS	MINIMUM WINDING AREA (mm ²)	NOMINAL WINDING WIDTH (mm)	AVERAGE LENGTH OF TURN (mm)	TYPE NUMBER
1	15.4	6.5	32.0	CP-E13/6/6-1S