

FERROXCUBE

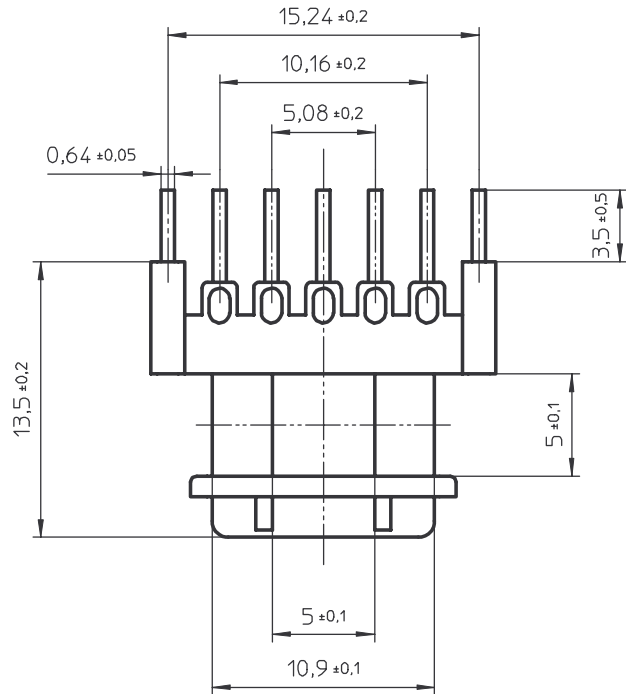

HOLE PATTERN

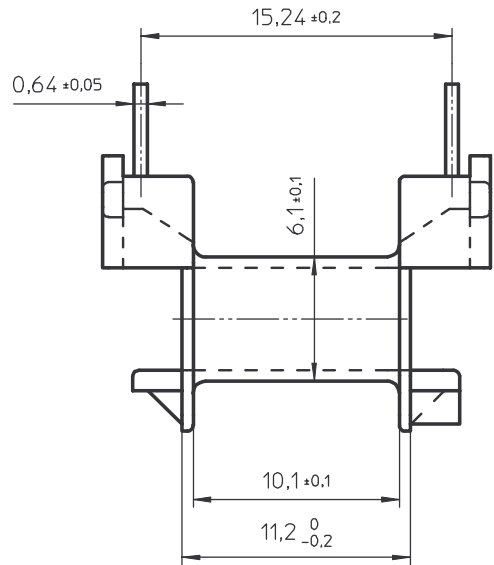
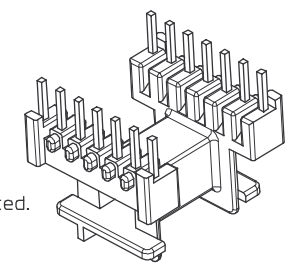
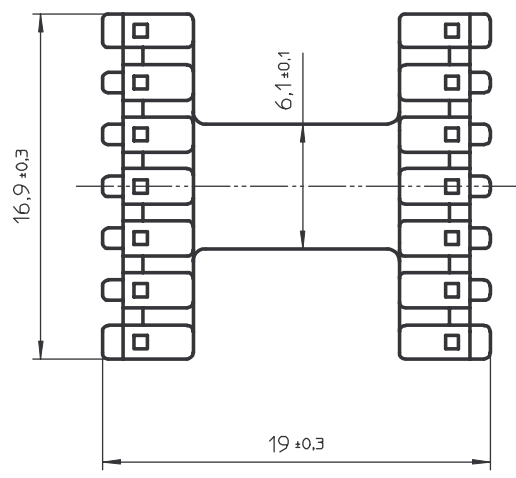
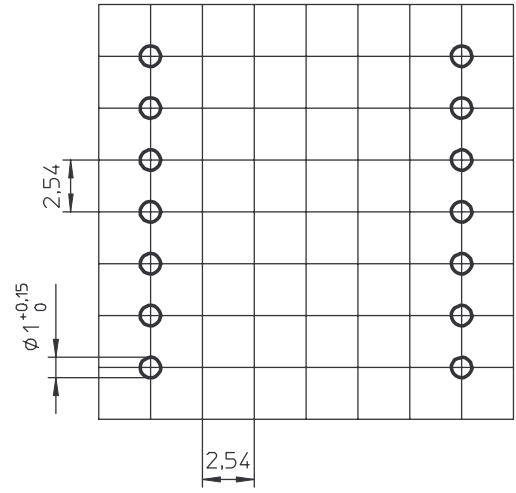

- Coil former material: Sumikon PM9820 (PF), glass-reinforced.
- UL file number: E41429 - UL94V-0.
- Pin material: Copper-clad steel, SnPb plated.
- Max. operating temp.: acc. to IEC 60 085 class H, 180°C.
- Resistance to soldering heat: acc. to IEC 60 068-2-20 Part 2, Test Tb, method 1B, 350°C - 3,5s
- Solderability: acc. to IEC 60 068-2-20 Part 2, Test Ta, method 1, 235°C - 2s
- Min. winding area: 22 mm .
- Mean length of turn: 33 mm.

CLASSNO.				01-11-12	
NAME		CSH-E16/8/5-1S-14P		4322 021 03921	
NAAM					
MPA		CHECK CONTR.		001	
		DAT.		01-11-12	
		Property of		112-001	
		Eigendom van		A3	
		© FERROXCUBE 2000			