



a



b



c



d



e



f

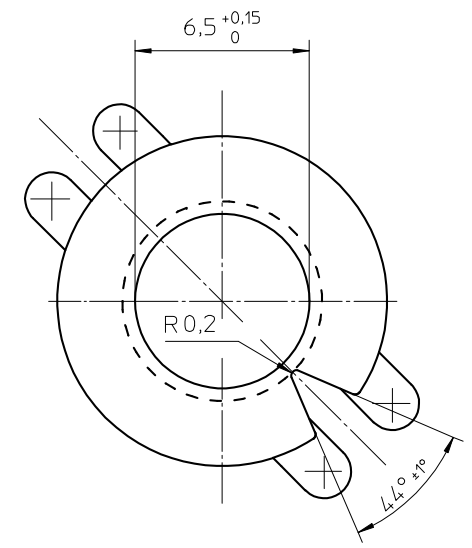
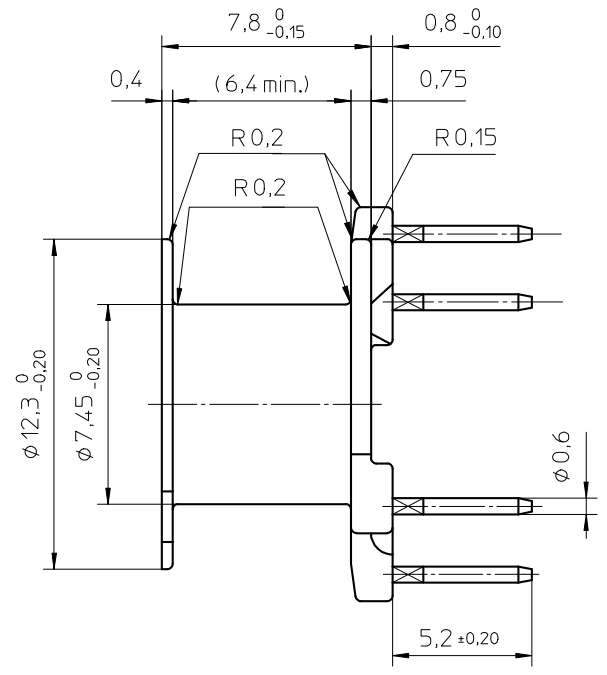
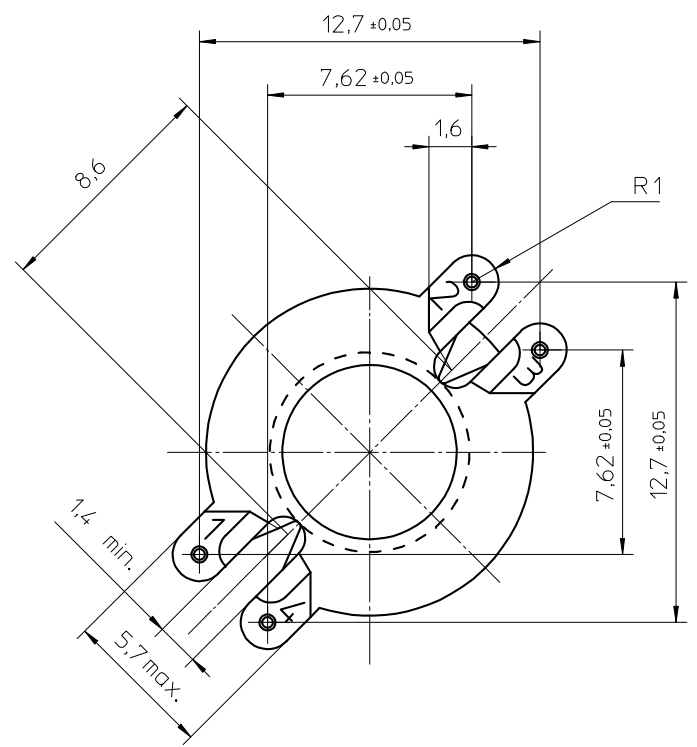

**HOLE PATTERN:**

Space requirement 6x6 pitch.

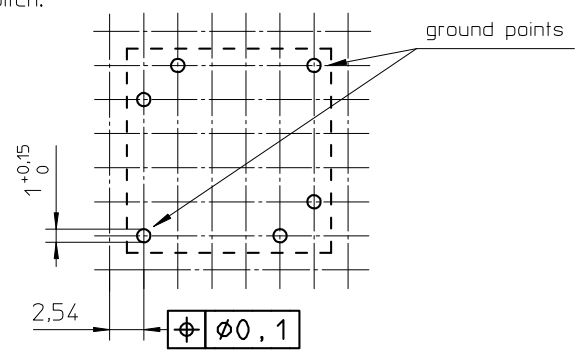

- Coil former material: Sumikon PM-9630 (PF), glass-reinforced.  
UL file number: E41429 - UL94V-0.
- Pin material: CuSn - Ni flash, Sn plated.
- Max. operating temp.: acc. to IEC 60 085 class H, 180°C.
- Resistance to soldering heat: acc. to IEC 60 068-2-20 Part 2, Test Tb, method 1B, 350°C-3,5s.
- Solderability: acc. to IEC 60 068-2-20 Part 2, Test Ta, method 1, 235°C-2s.
- Min. winding area: 15 mm<sup>2</sup>.
- Mean length of turn: 30 mm.

CLASSNO.		CSV-RM6S/R-1S-4P-IZ		4322 021 06891		07-11-08	
NAME NAAM	A. Wojtasz	SUPERS. VERV.	1	SPR BL	112	- 001	010
MPA	CHECK CONTR.	DAT.	07-11-08	Property of Eigendom van	© FERROXCUBE 2007		
							A3