

FERROXCUBE

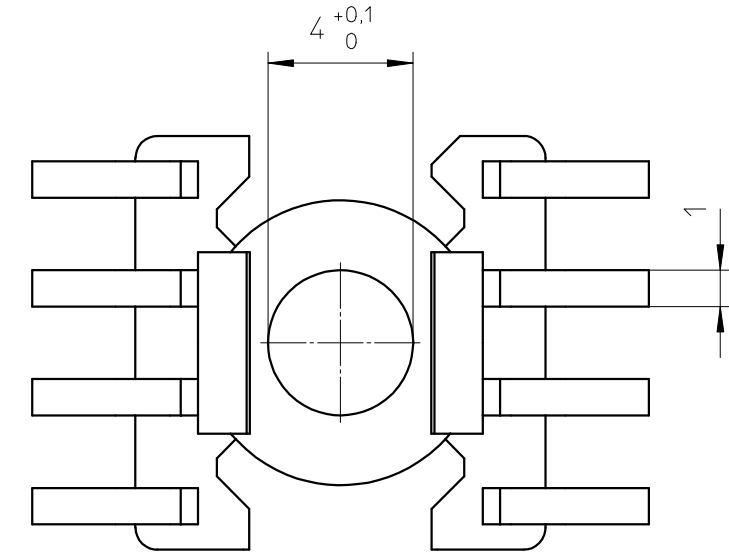

PROPOSED PAD ARRANGEMENT:

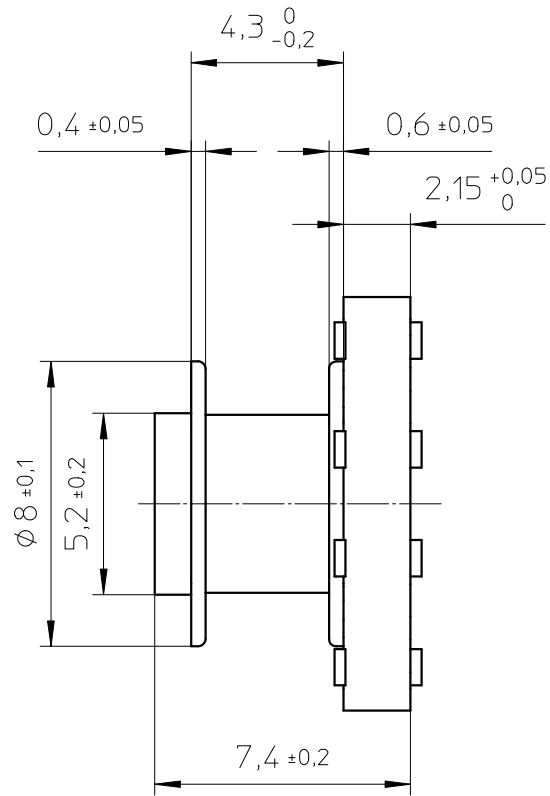
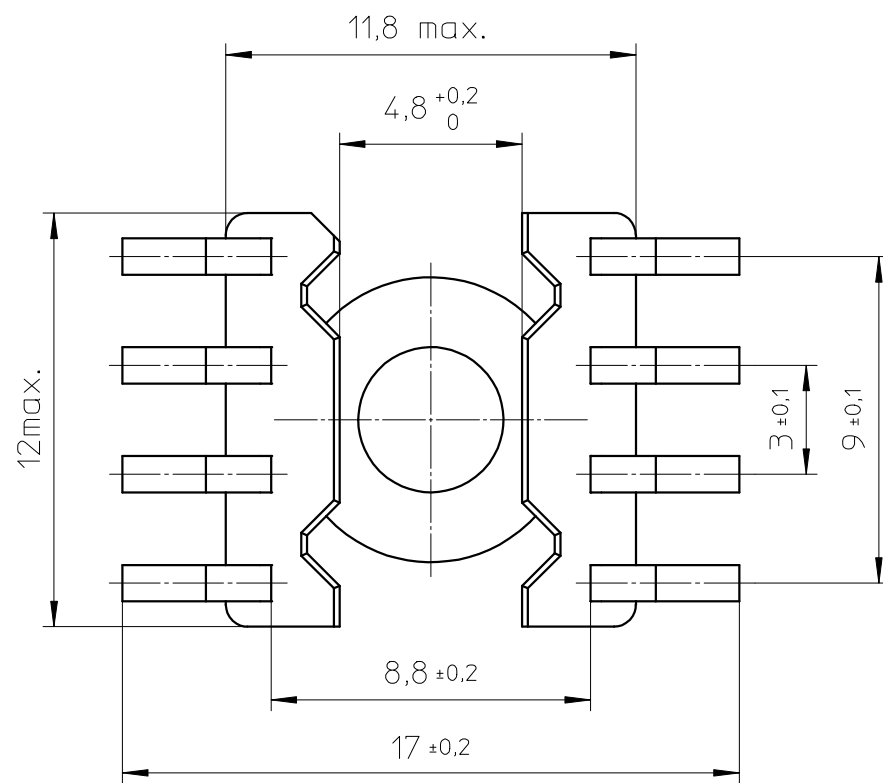
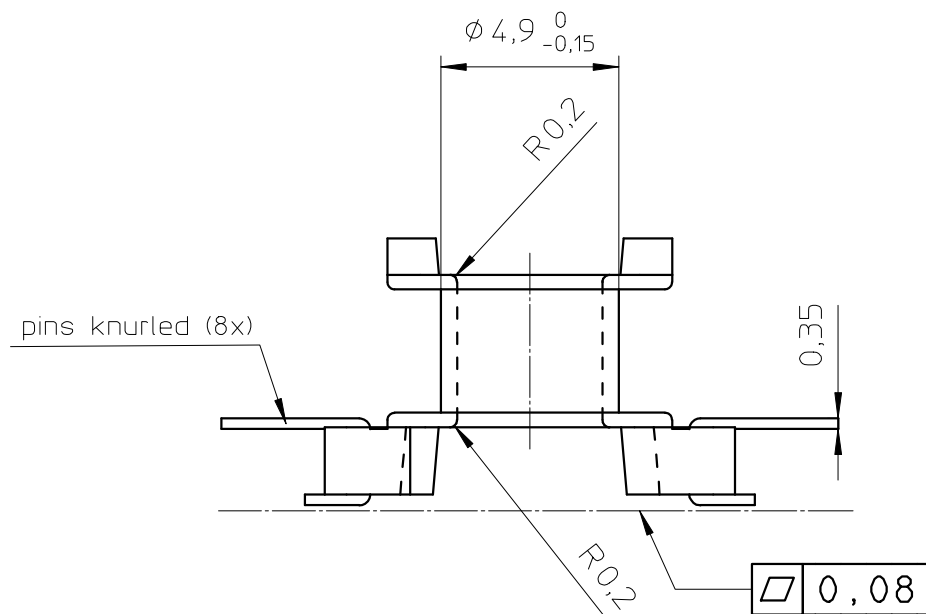
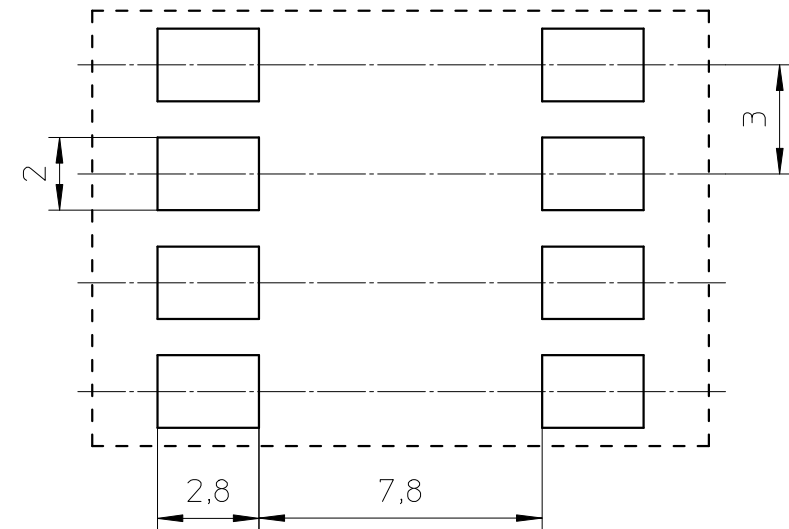

Coil former material:

Sumikon PM9630 (PF), glass-reinforced.

Pin material:

UL file number: E41429(M) - UL94V-0.

Max. operating temp.:

CuSn - Ni flash, Sn plated.

Resistance to soldering heat:

acc. to IEC 60 085 class F, 155°C.

Solderability:

acc. to IEC 60 068-2-20 Part 2, Test Tb, method 1B, 350°C - 3,5s.

acc. to IEC 60 068-2-20 Part 2, Test Ta, method 1, 235°C - 2s.

CLASS.NO.	CSVS-RM4/LP-1S-8PL		4322 021 03261	99-05-31
00-07-24				00-07-24
				01-06-27
				06-06-28
				06-07-20
NAME NAAM MPA	A.Wojtasz	SUPERS. VERY. VERV.	001 SH SH BL BL 112 - 001	069
CHECK CONTR.	DAT. 99-03-15	Property of Eigendom van	© FERROXCUBE 2000	
				A3

