

DATA SHEET

P11/7/I

P cores and accessories

Supersedes data of September 2004

2008 Sep 01

CORE SETS

Effective core parameters

SYMBOL	PARAMETER	VALUE	UNIT
$\Sigma(l/A)$	core factor (C1)	0.860	mm ⁻¹
V_e	effective volume	309	mm ³
l_e	effective length	16.3	mm
A_e	effective area	19.0	mm ²
A_{min}	minimum area	13.7	mm ²
m	mass of set	≈ 1.9	g

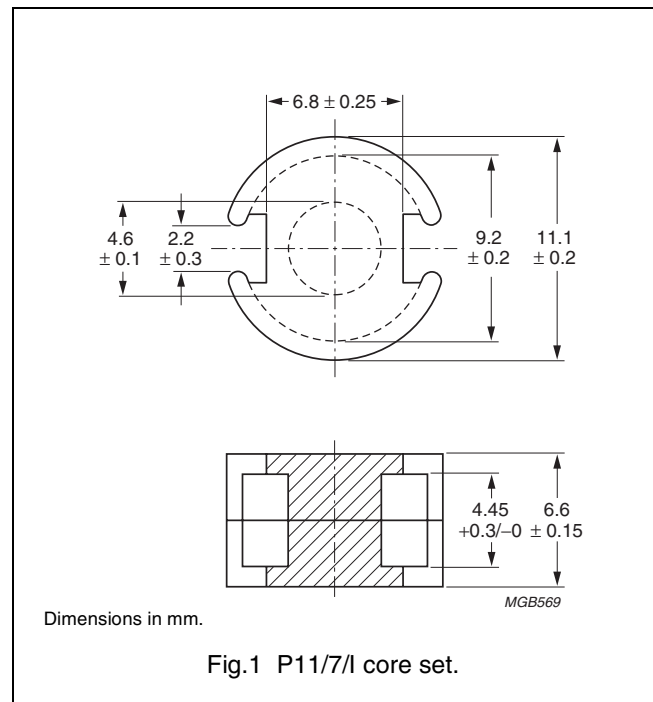

Core sets for general purpose transformers and power applications

Clamping force for A_L measurements, 10 ± 5 N.

GRADE	A_L (nH)	μ_e	AIR GAP (μ m)	TYPE NUMBER
3C81	63 ± 3%	≈ 43	≈ 500	P11/7/I-3C81-A63
	100 ± 3%	≈ 68	≈ 290	P11/7/I-3C81-A100
	160 ± 3%	≈ 109	≈ 170	P11/7/I-3C81-A160
	250 ± 5%	≈ 171	≈ 100	P11/7/I-3C81-A250
	315 ± 5%	≈ 215	≈ 75	P11/7/I-3C81-A315
	2100 ± 25%	≈ 1430	≈ 0	P11/7/I-3C81
3C91 <small>des</small>	2100 ± 25%	≈ 1430	≈ 0	P11/7/I-3C91
3F3	63 ± 3%	≈ 43	≈ 500	P11/7/I-3F3-A63
	100 ± 3%	≈ 68	≈ 290	P11/7/I-3F3-A100
	160 ± 3%	≈ 109	≈ 170	P11/7/I-3F3-A160
	250 ± 5%	≈ 171	≈ 100	P11/7/I-3F3-A250
	315 ± 5%	≈ 215	≈ 75	P11/7/I-3F3-A315
	1750 ± 25%	≈ 1195	≈ 0	P11/7/I-3F3

P cores and accessories

P11/7/I

Properties of core sets under power conditions

GRADE	B (mT) at	CORE LOSS (W) at			
	H = 250 A/m; f = 25 kHz; T = 100 °C	f = 25 kHz; B̂ = 200 mT; T = 100 °C	f = 100 kHz; B̂ = 100 mT; T = 100 °C	f = 100 kHz; B̂ = 200 mT; T = 100 °C	f = 400 kHz; B̂ = 50 mT; T = 100 °C
3C81	≥320	≤ 0.07	–	–	–
3C91	≥315	–	≤ 0.016 ⁽¹⁾	≤ 0.12 ⁽¹⁾	–
3F3	≥315	–	≤ 0.04	–	≤ 0.06

Note

1. Measured at 60 °C.

BOBBINS AND ACCESSORIES

Coil formers, winding data and mounting parts are equal to those of “P11/7”, but “area product” is different.

Winding data and area product (for P11/7/I) for CP-P11/7-1S coil former

NUMBER OF SECTIONS	WINDING AREA (mm ²)	MINIMUM WINDING WIDTH (mm)	AVERAGE LENGTH OF TURN (mm)	AREA PRODUCT Ae x Aw (mm ⁴)	TYPE NUMBER
1	4.8	3.1	22.6	91.2	CP-P11/7-1S

Winding data and area product (for P11/7/I) for CP-P11/7-A coil former

NUMBER OF SECTIONS	MINIMUM WINDING AREA (mm ²)	NOMINAL WINDING WIDTH (mm)	AVERAGE LENGTH OF TURN (mm)	AREA PRODUCT Ae x Aw (mm ⁴)	TYPE NUMBER
1	4.77	3.42	22.7	90.6	CP-P11/7-1S-A
2	2 × 2.00	2 × 1.52	22.7	2 × 38.0	CP-P11/7-2S-A
3	3 × 1.16	3 × 0.91	22.7	3 × 22.0	CP-P11/7-3S-A



DATA SHEET STATUS DEFINITIONS

DATA SHEET STATUS	PRODUCT STATUS	DEFINITIONS
Preliminary specification	Development	This data sheet contains preliminary data. Ferroxcube reserves the right to make changes at any time without notice in order to improve design and supply the best possible product.
Product specification	Production	This data sheet contains final specifications. Ferroxcube reserves the right to make changes at any time without notice in order to improve design and supply the best possible product.

DISCLAIMER

Life support applications — These products are not designed for use in life support appliances, devices, or systems where malfunction of these products can reasonably be expected to result in personal injury. Ferroxcube customers using or selling these products for use in such applications do so at their own risk and agree to fully indemnify Ferroxcube for any damages resulting from such application.

PRODUCT STATUS DEFINITIONS

STATUS	INDICATION	DEFINITION
Prototype		These are products that have been made as development samples for the purposes of technical evaluation only. The data for these types is provisional and is subject to change.
Design-in		These products are recommended for new designs.
Preferred		These products are recommended for use in current designs and are available via our sales channels.
Support		These products are not recommended for new designs and may not be available through all of our sales channels. Customers are advised to check for availability.